

## SINGLE SPORTS EXHAUST CROSS BOX

### TRIUMPH SPITFIRE IV & 1500

Part Number: **RL1615SS**



We can only offer the below as a guide and advise you to carefully study the system and its assembly before attempting to fit your car. Always revert to the workshop manual. Obtain clear safe access to the underside of the vehicle, using axle stands, ramp or pit.

1. Disconnect the battery
2. Starting from the front, drain the cooling system, then remove the old cast iron manifold, inlet manifold, carbs, and fittings. Ensure you note the position of the manifold fittings on removal. Check the condition of the manifold studs, replace where necessary.
3. Work towards the rear of the vehicle, removing the existing exhaust system and fittings. Keep any bracket for reference or future use.
4. Clean the cylinder head to manifold mating face, and using the new gasket, trail fit the tubular manifold. Due to manufacturing variations, you may need to lightly 'dress' the stud slots with a round file. When you are satisfied with the fit, bolt up the exhaust and inlet manifold assembly.
5. Fit the two collector clamps over the two short tube studs and interlock them to keep them near to the front of the pipe. These are a tight fit, and it may be necessary to file a small 'flat' on the clamps before assembly. Working under the car, fit the collector pipe to the manifold clamps, then fit the adaptor sleeve the intermediate pipe and fit this assembly to the manifold collector.
6. Slide the rear support clamp (GEX7509) over the intermediate pipe, and then fit the rear silencer to the existing hanging points in the boot floor using the flexible straps and fitting supplied in the fitting kit. Working back from the manifold, fit the clamps and apply assembly paste adjusting and aligning system, tightening the clamps.

#### QUALITY PARTS AND ACCESSORIES



Triumph House, Sleaford Road, Bracebridge Heath, Lincoln LN4 2NA, England

UK Tel: +44 (0)1522 568000 | USA Tel: 1 855 746 2767 | Fax: +44 (0)1522 567600 | E-mail: [sales@rimmerbros.com](mailto:sales@rimmerbros.com)

[www.rimmerbros.com](http://www.rimmerbros.com)

Item 1 showing area to be filed

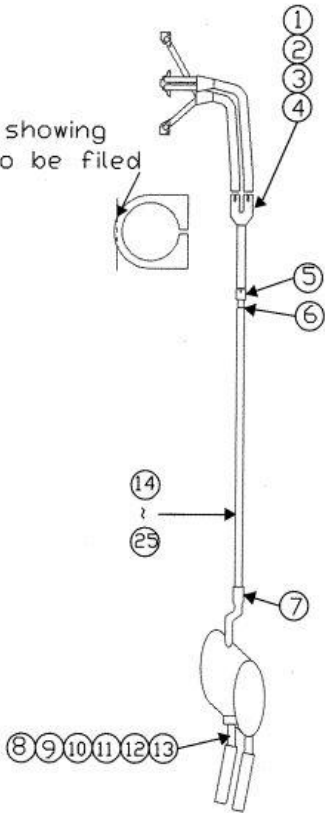

Item No.	Description	Qty
1	42mm Exhaust clamp	2
2	Bolt 5/16" x 2 3/4"	2
3	Spring Washer 5/16" ID	2
4	Nut 5/16" UNF	2
5	Exhaust Clamp 54mm	1
6	Exhaust Clamp 45mm	1
7	Exhaust Clamp 45mm	1
8	Silencer Strap	2
9	Tube Spacing Sleeve	4
10	Clamp plate	4
11	Spring Washer 5/16" ID	4
12	Set Screw 5/16" x 1"	4
13	Nut 5/16" UNF	4
14	Exhaust bracket	1
15	Rubber washer Flat	1
16	Rubber washer Stepped	1
17	Washer 5/16" x 1"	1
18	Plain Washer 5/16" ID	1
19	Nyloc Nut 5/16"	1
20	Exhaust Clamp	1
21	Bolt 5/16" x 2 3/4"	1
22	Plain Washer 5/16" ID	1
23	Spring Washer 5/16" ID	1
24	Nut 5/16" UNF	1
25	Bolt 5/16" x 1 1/4"	1

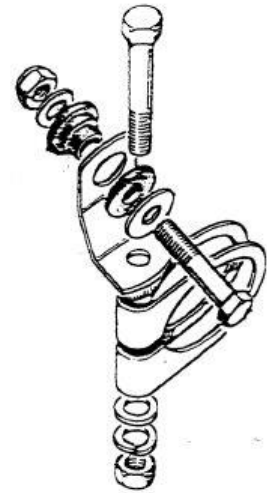
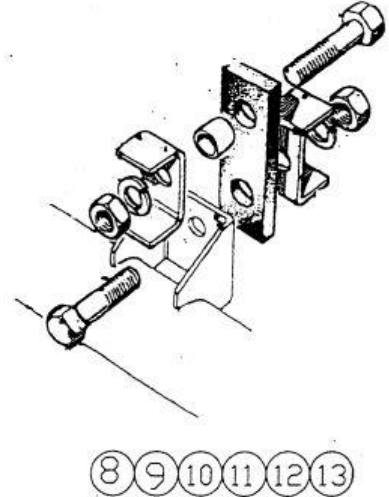

This diagram is not to scale  
& is to help locate the fittings only



## QUALITY PARTS AND ACCESSORIES



Triumph House, Sleaford Road, Bracebridge Heath, Lincoln LN4 2NA, England

UK Tel: +44 (0)1522 568000 | USA Tel: 1 855 746 2767 | Fax: +44 (0)1522 567600 | E-mail: sales@rimmerbros.com

[www.rimmerbros.com](http://www.rimmerbros.com)